

**Instruction Sheet
for the PASCO
Model ME-9204B**

ACCESSORY PHOTOGATE

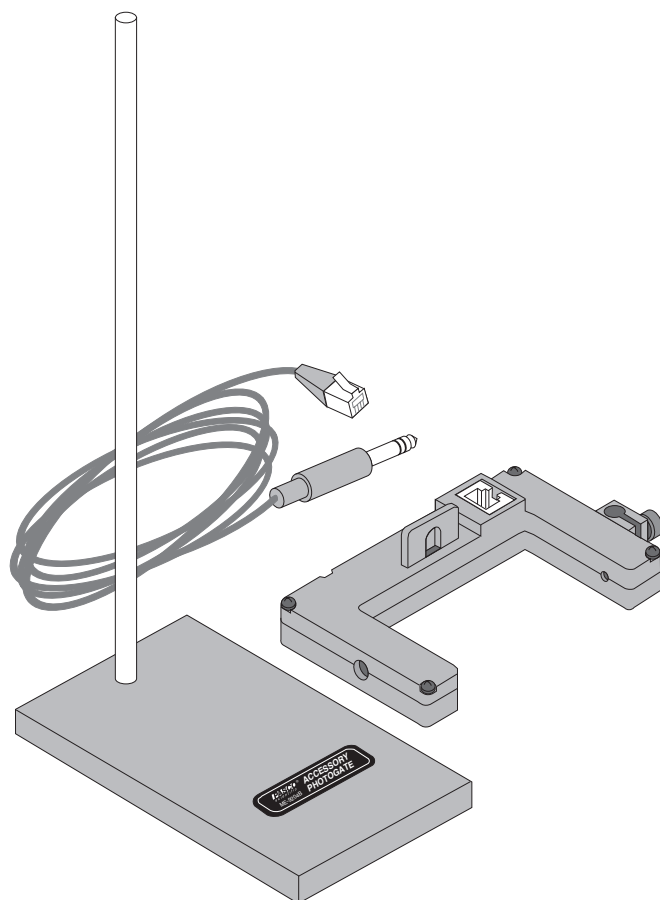

Introduction

The PASCO Model ME-9204B Accessory Photogate features a Photogate Head with a narrow infrared beam and a fast fall time that provide very accurate signals for timing. When the infrared beam between the source and detector is blocked, the output of the photogate is low, and the red LED (light emitting diode) on the photogate goes on. When the beam is not blocked, the output is high, and the LED is off.

The cable assembly included with the Accessory Photogate is detachable from the unit. One end of the cable is a RJ12 telephone plug that connects to the RJ12 modular jack in the photogate housing. At the other end, a stereo phone plug connects directly into a PASCO Photogate Timer (ME-9206B and ME-9215B) or into any PASCO interface with digital channels (*ScienceWorkshop* 500 I and 700 I). Please note that the ME-9215B has a memory function which allows signals from two photogates (the built-in photogate on the ME-9215B and the ME-9204B) to be stored and retrieved.

The Photogate Head also includes a small rod clamp and thumbscrew for attaching the unit to the base and support rod included with the product, or to any quarter inch diameter support rod.

Additional Features

The raised slot on the housing provides a seat for attaching the PASCO ME-9450 Super Pulley.

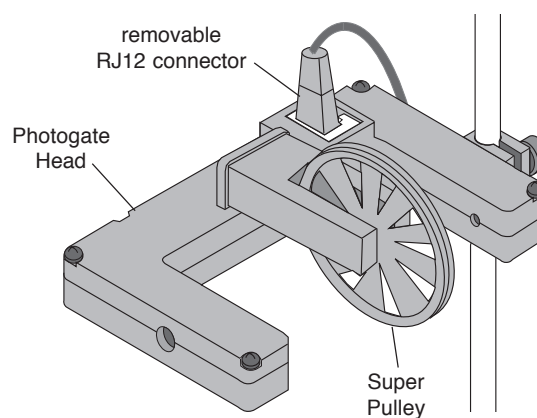

© 1997 PASCO scientific

This instruction sheet edited by: Martina Graham

The Photogate Head can be mounted on a support rod of up to half inch in diameter by attaching a PASCO ME-8744 Adjustable Angle Clamp. It is necessary to remove the “mobile” rod clamp from the clamp assembly and secure the “fixed” part of the clamp assembly to the 1/4-20 thread provided in the photogate housing opposite the side of the small rod clamp. Rotate the equipment to the correct orientation and then secure it with the locking knob.

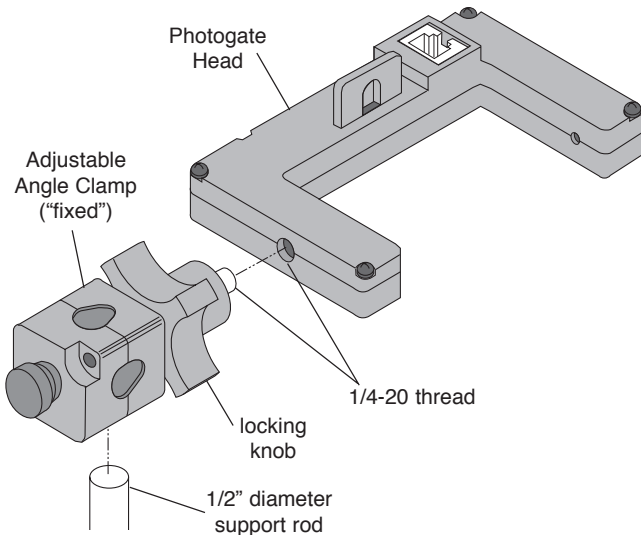

The Photogate Head can also be attached to the side of a PASCO Dynamics Track with an IDS mounting bracket (part of PASCO ME-9471 IDS Photogates and Fences). It is necessary to remove the small rod clamp from the photogate housing.

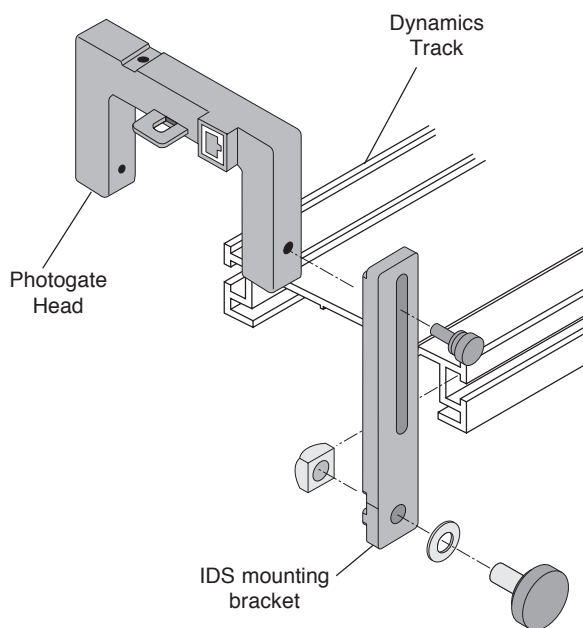

Operation

- ① Clamp the Photogate Head to the support rod.
- ② Position the photogate so the object to be timed will pass through the photogate, blocking the beam. (See Figure “Photogate with Pendulum”). To minimize parallax error, pass the object as close to the detector as possible, with the line of travel perpendicular to the beam. Loosen the clamp screw to change the angle or height of the photogate.
- ③ Plug the RJ12 phone plug from the cable assembly into the modular phone jack on the photogate housing.
- ④ Plug the stereo phone plug at the other end of the cable assembly into the timer, adapter cable, or interface.
- ⑤ Test the operation of the photogate by watching the LED when the beam is blocked.

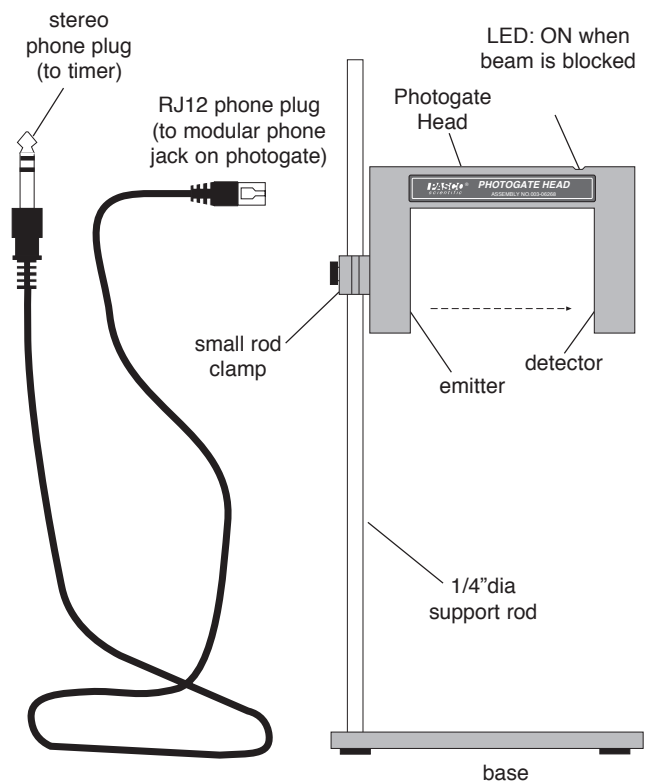

Accessory Photogate

NOTES:

- The actual length of an object passing through the photogate may be slightly different than the effective length seen by the photogate. To determine the effective length, push the object through the photogate, and measure the distance moved by the object from where the LED first comes ON to where it goes off. Use this effective length, rather than the actual length, in calculations. For example, if you were measuring the speed of the object, you would divide the effective length by the time during which the object blocked the photogate beam.
- A stereo phone plug extension cord, such as PASCO Model PI-8117, will increase the separation between the photogate and the timer.

Experiments

Refer to the experiment guide that comes with your PASCO equipment (e.g., Introductory Dynamics System).

Photogate Specifications

Detector rise time: < 500 ns

Detector fall time: < 50 ns

Parallax error: For an object passing within 1 cm of the detector, with a velocity less than 10 m/s, the difference between the true and effective length is less than 1 mm.

Power requirements: 5 VDC \pm 5% at 45 mA.

Infrared source: Peak at 880 nm.

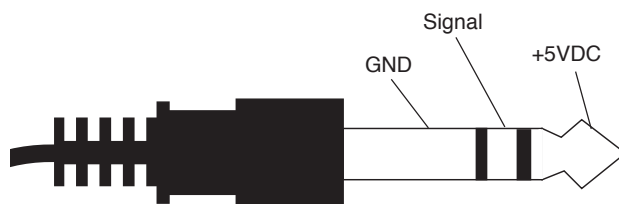

Stereo Phone Plug

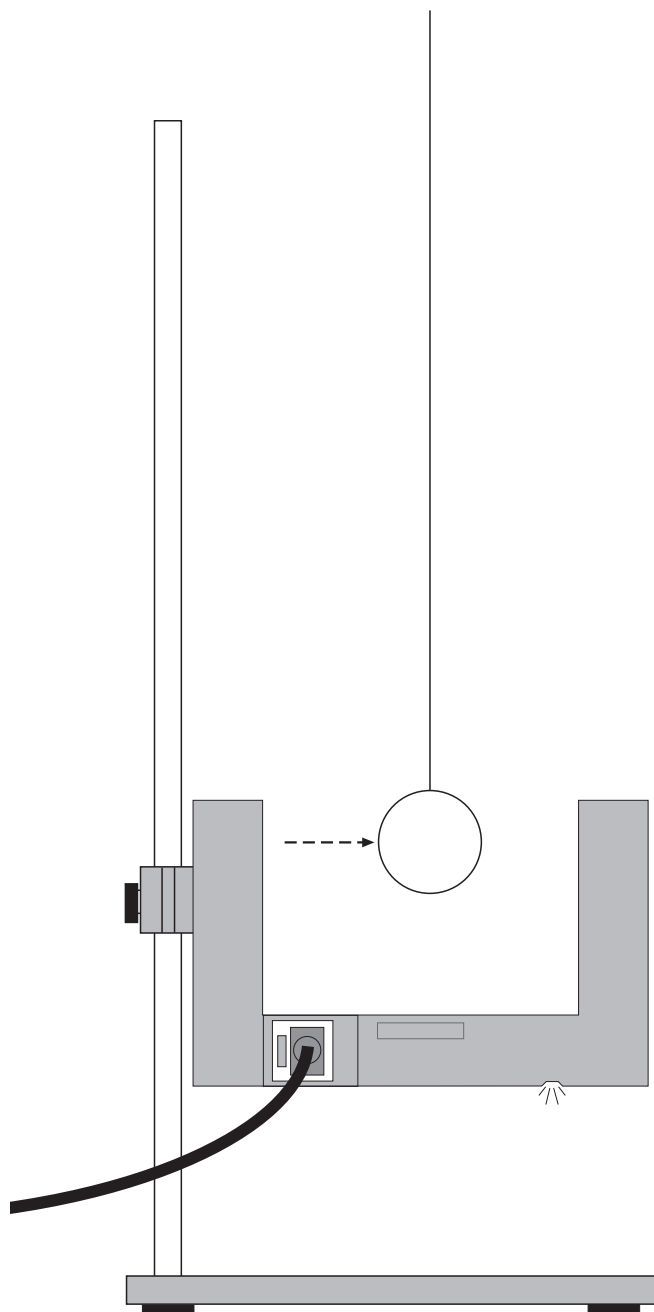

Photogate with Pendulum

Limited Warranty

PASCO scientific warrants the product to be free from defects in materials and workmanship for a period of one year from the date of shipment to the customer. PASCO will repair or replace, at its option, any part of the product which is deemed to be defective in material or workmanship. The warranty does not cover damage to the product caused by abuse or improper use. Determination of whether a product failure is the result of a manufacturing defect or improper use by the customer shall be made solely by PASCO scientific. Responsibility for the return of equipment for warranty repair belongs to the customer. Equipment must be properly packed to prevent damage and shipped postage or freight prepaid. (Damage caused by improper packing of the equipment for return shipment will not be covered by the warranty.) Shipping costs for returning the equipment, after repair, will be paid by PASCO scientific.

Feedback

If you have any comments about the product or manual, please let us know. If you have any suggestions on alternate experiments or find a problem in the manual, please tell us. PASCO appreciates any customer feedback. Your input helps us evaluate and improve our product.

To Reach PASCO

For technical support, call us at 1-800-772-8700 (toll-free within the U.S.) or (916) 786-3800.

fax: (916) 786-3292

e-mail: techsupp@pasco.com

web: www.pasco.com